

Replacing Detached Bookblock into Cover

The hinge is the weakest interior part of the book and the one most often broken from repeated use.

If both hinges are broken do the following:

1. Cut through the remaining super to free the cover completely
2. Remove as much of the paper lining the spine as possible
 1. Remove all of the super covering the spine
 2. Pull the super off the cover
 3. Remove as much of the endpaper as necessary, or
 4. Leave endpaper intact as it can be covered with a new endpaper

If only one hinge is broken do the following:

1. Cut through the remaining super to free one side of the cover

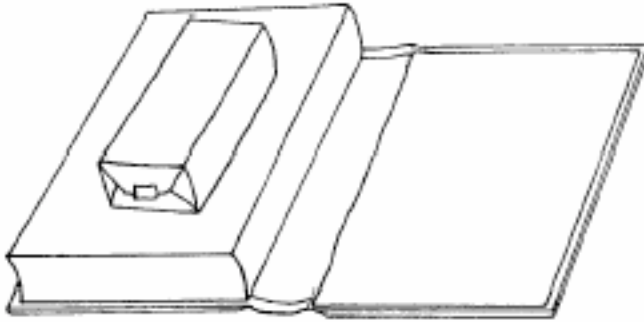

2. Remove any frayed parts of the original super

Continue as follows for both procedures:

1. Reline the spine with a layer of endsheet paper and make sure the grain of the endpaper strip parallels the spine:

OVER

Replacing detached book block into cover (2)

- . Measure the thickness and height of the spine

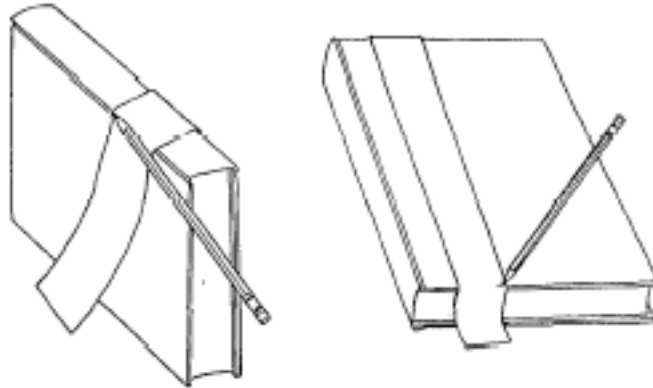

- . Cut two pieces of endsheet paper to the exact height and width of the spine
- . Apply a layer of PVA to one spine liner
- . Adhere the spine liner to the spine and smooth over with the bone folder

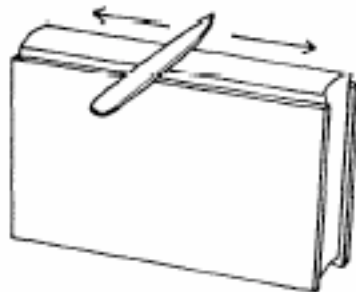

- . Let dry for at least 10 minutes
5. Cut a piece of new super to 1/2" less than the height of the bookblock
NOTE: For especially large or heavy book cut two pieces of super or double the one layer
 6. Using the thickness of the bookblock
 - a. Add 3" to thickness of the bookblock if replacing both hinges
 - b. Add 1 1/2" to thickness of the bookblock if replacing one hinge

OVER

Replacing detached book block into cover (3)

7. Center the super on the spine
 - . Let 1-1/2" of the super extend on either side of the spine if doing both hinges

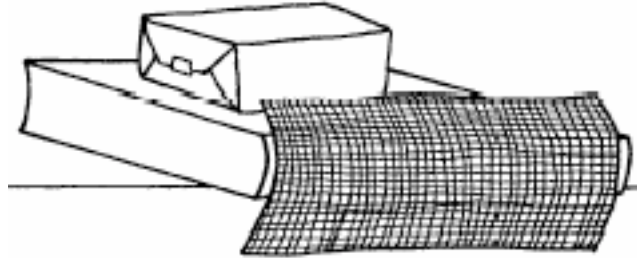

OR

- b. Let 1-1/2" of the super extend on just one side of the spine if doing one hinge
8. Apply PVA to the spine
9. Adhere the super to the spine leaving a space of 1/4" on top and bottom

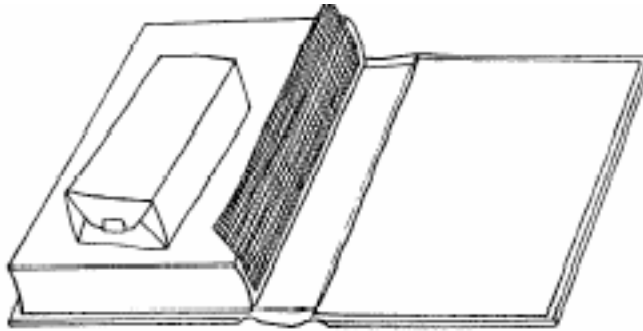

10. Rub the adhesive well into the super by using your finger
11. Adhere the second endsheet spine liner on top of the super
4. Rub down the second liner well with the bone folder
13. Let dry for 15 minutes

To reattach the bookblock:

1. Center the book on the cover making sure the bookblock is right side up
2. Place two thicknesses of wax paper on top of the bookblock
3. Apply a strip of PVA to the board where the super will be attached
4. Bring the cover down over the super
5. Close the book
6. If only one hinge is replaced, leave the book under weights for an hour
1. If both hinges are replaced repeat steps 1-5, and let dry for several hours